

One-step recovery of nickel by an electrohydrometallurgical process

P. W. PAGE, N. P. BRANDON, M. N. MAHMOOD, P. O. FOGARTY

BP Research Centre, Chertsey Road, Sunbury-on-Thames, Middlesex TW16 7LN, Great Britain

Received 25 November 1991; accepted 28 January 1992

The one-step electroleaching-electrowinning of nickel from violarite and pentlandite iron-nickel sulphide concentrates has been demonstrated using an electrochemical cell fitted with a cation exchange membrane. Oxidants were electrogenerated in the anode compartment, which contained a slurry of the concentrate, and dissolved nickel electrowon in the cathode compartment. Nickel powder of greater than 99% purity with an iron content of 0.2% was obtained

1. Introduction

Extracting base metals from sulphides via a hydro-metallurgical route avoids the environmental problems associated with SO₂ emission during pyrometallurgical treatment. Conventional hydrometallurgical processes involve a number of steps, frequently including leaching and electrowinning. Electrohydrometallurgical (EHM) processes combine leaching and electrowinning to give a one-step route to the oxidative recovery of base metals. Thus, in an EHM process, the oxidant is electrogenerated in an electrochemical cell, the anode of which contains a slurry of metal concentrate, and the leached metal is electrowon at the cathode. Examples include the Dextec [1], Cymet [2], and Electroslurry [3] processes for the extraction of copper from copper sulphides. These are based on the leaching of copper using anodically generated ferric ions, followed by a plating step to recover the copper.

Little work has been carried out into the extraction of nickel from its concentrates by an EHM process. Nickel is typically found in the form of nickel-iron sulphides such as pentlandite (Fe,Ni)₉S₈ or violarite FeNi₂S₄. An ideal EHM process should, therefore, selectively leach the nickel-rich sulphides, reject the iron impurity from the leach liquor, and electrowin the nickel values. In addition, sulphate formation should be minimized as it increases the oxidant (and therefore energy) requirement for nickel dissolution, leads to a pH imbalance through the accompanying generation of protons, and has a cost associated with its removal by, for example, precipitation using barium salts. The aim of this work was to investigate the major variables affecting such an EHM process, and to demonstrate that electroleaching could be coupled with electrowinning in a one-step route to nickel recovery.

Nickel can be dissolved anodically from violarite and pentlandite under acidic conditions according to Reactions 1 and 2.

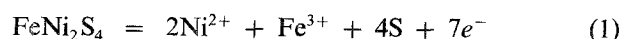

$$E = 0.37 + 0.017 \log [\text{Ni}^{2+}]$$

$$+ 0.008 \log [\text{Fe}^{3+}]$$



$$E = 0.204 + 0.013 \log [\text{Ni}^{2+}]$$

$$+ 0.011 \log [\text{Fe}^{3+}]$$

This can be achieved by the *in situ* electrogeneration of oxidants such as chlorine:

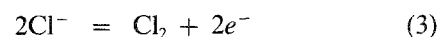

$$E = 1.36 - 0.0295 \log [\text{Cl}_2]/[\text{Cl}^-]^2$$



$$K = 4.66 \times 10^{-4}$$

By maintaining the pH of the anolyte solution between 2 and 4, ferric ions are selectively precipitated as goethite (FeOOH), producing a nickel-rich liquor with a low-iron content:



where

$$\log [\text{Fe}^{3+}] = -1.85 - 3\text{pH}$$

The use of an acidic pH should also restrict the oxidation of sulphide or sulphur to sulphate, as these reactions become less thermodynamically favourable under acidic conditions:

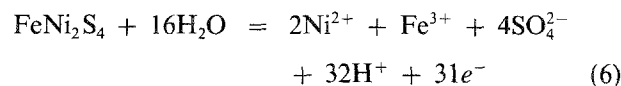

$$E = 0.35 - 0.061 \text{pH} + 0.004 \log [\text{Ni}^{2+}]$$

$$+ 0.002 \log [\text{Fe}^{3+}]$$

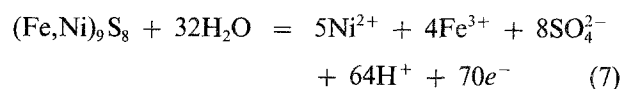

$$E = 0.309 - 0.054 \text{pH} + 0.004 \log [\text{Ni}^{2+}]$$

$$+ 0.0034 \log [\text{Fe}^{3+}] + 0.0068 \log [\text{SO}_4^{2-}]$$

When the leaching and electrowinning steps are combined, the dissolved nickel diffuses through a cation

Table 1. Chemical analysis of the principal elements in the violarite and pentlandite concentrates

Element	% in violarite	% in pentlandite
Nickel	8.3	16.1
Iron	37.8	26.0
Cobalt	0.2	0.3
Copper	0.3	1.1
Sulphur	36.4	26.7
Remainder	~20	~30

exchange membrane into the cathode compartment of the electrochemical cell where the nickel can be electrowon [4]:



Hydrogen evolution also occurs at the cathode, generating hydroxyl ions which can be used to neutralize protons produced in the anolyte:

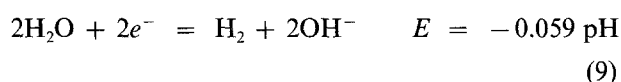

The EHM process investigated in this study was based on the leaching of a slurry of iron-nickel sulphide concentrate in an acidic chloride medium. Initially, the electroleaching step alone was investigated. This was followed by a study of the combined leaching-electrowinning process.

2. Experimental details

Two nickel-iron sulphide concentrates were tested, both originating from Western Australia: (i) a violarite concentrate containing 8% nickel and 38% iron and (ii) a pentlandite concentrate containing 16% nickel and 26% iron. Their chemical and mineralogical compositions are listed in Tables 1 and 2, respectively.

The slurry electrolysis cell used to study the electroleaching process is illustrated in Fig. 1. The cathode compartment contained four 5 mm diameter carbon rod cathodes and a pH electrode. It was separated from the anode compartment by an Ionics AR103 anion exchange membrane of exposed area 20 cm². The oxidant was generated at three 7 mm diameter carbon rod anodes masked to provide a total effective area of 50 cm². A constant current of 1 or 6 A was maintained using a Wenking HP72 potentiostat. The slurry was held in the anode compartment and stirred

Table 2. Mineralogical distribution of major minerals in the violarite and pentlandite concentrates

Vioiarite concentrate		Pentlandite concentrate	
Mineral	(%)	Mineral	(%)
Vioiarite (FeNi ₂ S ₄)	21	Pentlandite ([Fe,Ni] ₉ S ₈)	46
Pyrite (FeS ₂)	30	Pyrite (FeS ₂)	23
Pyrrhotite (FeS)	31	Chalcopyrite (CuFeS ₂)	3
Chalcopyrite (CuFeS ₂)	1	Silicates	28
Silicates	17		

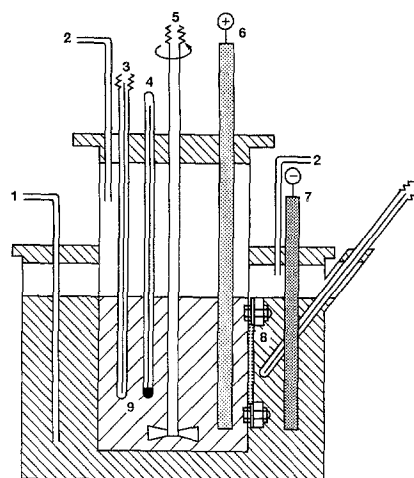

Fig. 1. Schematic of electroleaching cell. (1) Nitrogen inlet. (2) pH Buffer inlet. (3) pH electrode. (4) Thermometer. (5) Stirrer. (6) One of four graphite anodes. (7) One of three graphite cathodes. (8) Anionic ion exchange membrane. (9) Slurry of concentrate.

at 3000 r.p.m. using a paddle stirrer. Pulp density was typically 13.5% wt/vol. The temperature was controlled over the range 35–90°C by placing the cell in a thermostatically controlled oil bath. When simultaneous electroleaching-electrowinning was carried out, the carbon cathodes were replaced by a single titanium cathode of area 25 cm², and a Nafion® cation exchange membrane was used.

Generally, an electrolyte of 2 M sodium chloride was used as both anolyte and catholyte. The catholyte was nitrogen sparged and its pH maintained at 3 by the addition of concentrated hydrochloric acid. During the combined electroleaching-electrowinning tests, 30 g dm⁻³ boric acid was added to the catholyte to maintain the pH ~ 4, thereby preventing nickel hydroxide precipitation. The anolyte pH was first adjusted using hydrochloric acid, and then maintained by the addition of a solution of 5 M sodium hydroxide and 2 M sodium chloride. The addition of these buffering solutions was carried out automatically using a Metrohm Model 10 Combi-Titrator.

At the end of each test, the slurry was filtered and the cake washed with hot water. The filtrate was passed through a 0.5 µm Millipore filter to remove residual particles of sulphur and goethite. All the solids were dried, and their Fe, Ni, Co and Cu contents determined by atomic absorption spectroscopy after fusing a weighed sample with sodium peroxide and dissolving in acid. Another weighed sample was dissolved in 50% HCl at 90°C and the sulphate content measured using ion-exchange chromatography. The elemental sulphur content of the solids was determined by reacting with sulphite to form soluble thio-sulphate, and then titrating with iodine.

The filtrate was analysed for nickel, iron, cobalt and copper by atomic absorption spectroscopy, and for sulphate by ion-exchange chromatography. Chloride ion concentrations were determined by titration with standard silver nitrate solution. The impurity content of the electrowon nickel was analysed by atomic absorption after dissolving in acid.

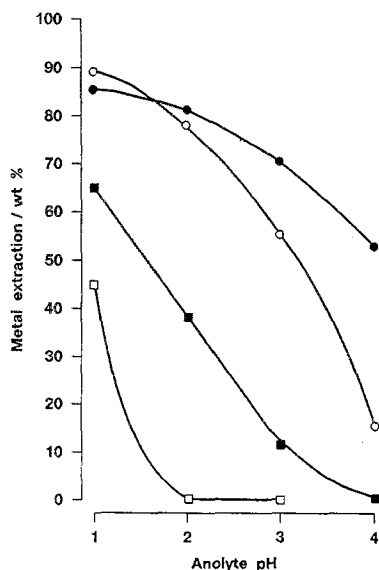

Fig. 2. Effect of anolyte pH on metal dissolution from the violarite concentrate after 14 h at 1 A and 90°C. (●) nickel, (○) cobalt, (■) copper, and (□) iron.

3. Results and discussion

3.1. Effect of pH

Figure 2 shows the effect of anolyte pH on the concentration of metals in solution after electroleaching the violarite concentrate for 14 h at 1 A. In practice, it would be necessary to prevent the build up of metallic impurities, most probably by precipitating them from the spent electrolyte [5]. The effect of pH on the selectivity of sulphide oxidation to elemental sulphur rather than sulphate is shown in Fig. 3. Both results demonstrate the importance of accurate pH control if nickel is to be efficiently extracted, whilst simultaneously precipitating the iron as goethite and minimizing sulphate formation. An anolyte pH of 3 was selected for the rest of the testwork as this gave over 70% nickel

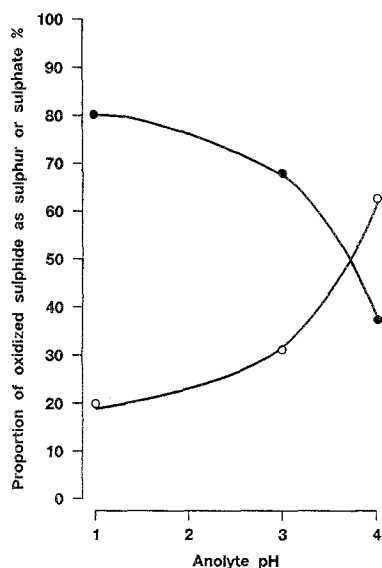

Fig. 3. Effect of anolyte pH on the selectivity of sulphur (●) and sulphate (○) production from the violarite concentrate after 14 h at 1 A and 90°C.

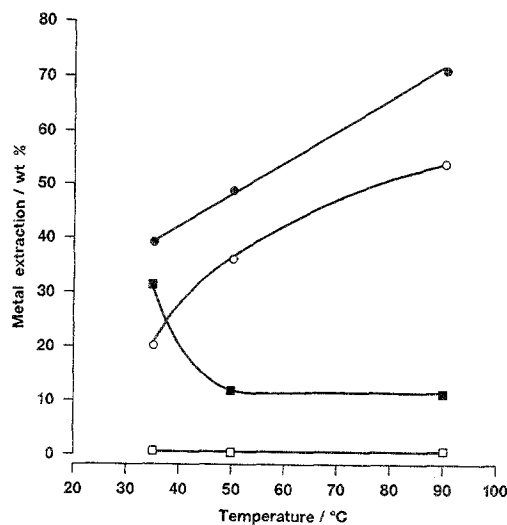

Fig. 4. Effect of temperature on metal dissolution from the violarite concentrate at pH 3 after 14 h at 1 A. (●) nickel, (○) cobalt, (■) copper, and (□) iron.

extraction and elemental sulphur production, with less than 0.3% dissolved iron.

At pH 3, the violarite concentrate required the addition of 0.15 g H⁺ to the catholyte per gram of nickel leached. This balanced the formation of 0.14 g H⁺ g⁻¹ Ni in the anolyte, demonstrating that a pH balance could be maintained by circulating catholyte back to the anolyte.

3.2. Effect of temperature

The effect of temperature on metal dissolution and sulphur/sulphate formation is shown in Figs 4 and 5, respectively, when electroleaching the violarite concentrate for 14 h at 1 A. The higher temperatures favoured both nickel extraction and elemental sulphur production. The level of dissolved iron remained low at all temperatures. The apparent activation energy for nickel dissolution was 4.3 kJ mol⁻¹, suggesting that the nickel dissolution process was not activation

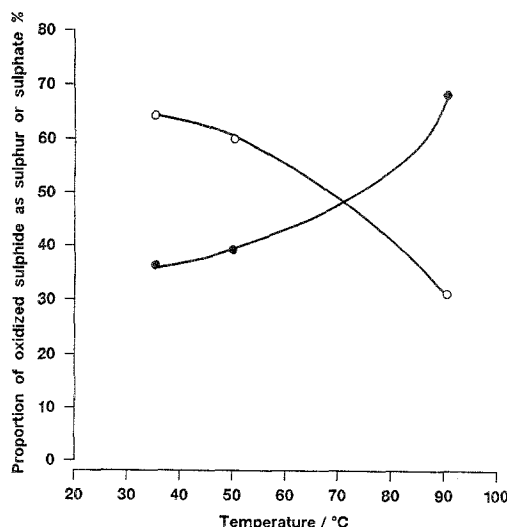

Fig. 5. Effect of temperature on the selectivity of sulphur (●) and sulphate (○) production from the violarite concentrate at pH 3 after 14 h at 1 A.

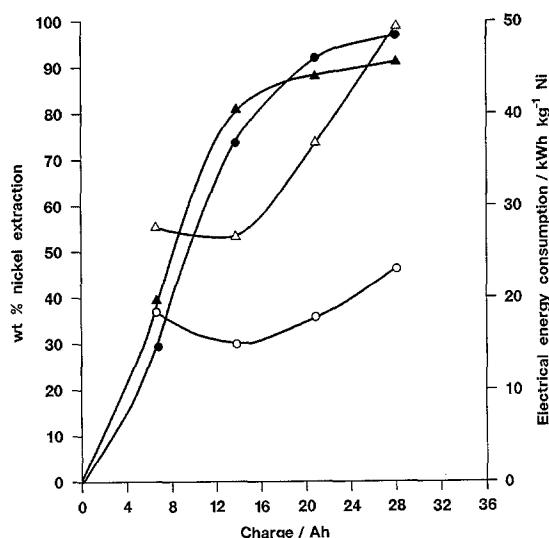

Fig. 6. Effect of charge passed on nickel extraction and electrical energy consumption (EEC) from both violarite and pentlandite concentrates with a current of 1 A at pH 3 and 90°C. Violarite (▲) % nickel, (△) EEC. Pentlandite (●) % nickel, (○) EEC.

controlled, but was governed by diffusion of the oxidant through a goethite and sulphur film formed around the partially oxidized sulphide particles.

3.3. Effect of charge

In order to determine the effect of charge passed and current density on the energy efficiency of nickel extraction, it was necessary to establish the theoretical charge required to extract 1 kg of nickel, assuming 100% selectivity and 100% current efficiency. If both concentrates break down by the most efficient path (i.e. via Reactions 1 and 2) then a charge of 1.6 and 2.2 kAh is required to obtain 1 kg of nickel from the violarite and pentlandite concentrates, respectively. The experimental charge requirement was calculated from laboratory data, and compared with the theoretical charge to give the current efficiency, I_{eff} . Multiplying the experimental charge by the cell voltage (typically 3 V) gave the energy consumption in kWh kg⁻¹ nickel.

Figure 6 shows the effect of charge on nickel extraction and energy consumption for both the violarite and pentlandite concentrates. The extraction of nickel increased almost linearly with charge up to 14 Ah, but then the increase in extraction became less charge dependent. This may have been due to the formation of a film of reaction products, such as sulphur and goethite, around the mineral particles with time, forming a barrier between the nickel sulphides and the oxidant. Under these conditions, the chlorine may have preferentially oxidized the sulphur, forming sulphate. This is indicated in Fig. 7, where the proportion of elemental sulphur produced starts to fall above 14 Ah. Additionally, other non-nickel bearing sulphides in the concentrate may have been oxidized. Consequently, the energy consumption (Fig. 6) reached a minimum (25 kWh kg⁻¹ Ni for violarite, 14 kWh kg⁻¹ Ni for pentlandite), and the I_{eff} value a maximum (20% for violarite, 48% for pentlandite),

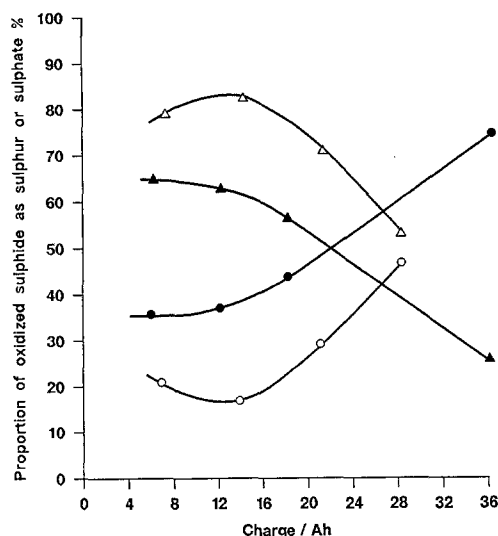

Fig. 7. Effect of charge passed on the selectivity of sulphur/sulphate production from both violarite and pentlandite concentrates with a current of 1 A at pH 3 and 90°C. Violarite (▲) sulphur, (●) sulphate. Pentlandite (△) sulphur, (○) sulphate.

around 14 Ah. Nickel extraction was always more energy efficient with the pentlandite concentrate, and the yield of elemental sulphur was also higher, demonstrating that the efficiency of the electroleaching step was dependent on both the charge passed, and the mineralogy of the concentrate.

3.4. Effect of calcium chloride

Tests were carried out with calcium chloride as the supporting electrolyte in place of sodium chloride, the aim being to precipitate out unwanted sulphate as CaSO₄ during leaching. Table 3 compares the results of electroleaching in 2 M CaCl₂ and 2 M NaCl. After passing a charge of 24 Ah the level of sulphate in the anolyte was only 0.4 g dm⁻³ with CaCl₂, as compared to 16.5 g dm⁻³ with NaCl. Additionally, more than 99% of the sulphate reported to the solid residue with the calcium chloride. However, the disadvantage of using CaCl₂ was that the calcium sulphate increased the thickness of the layer of oxidation products surrounding the partially leached sulphide particles. This inhibited nickel dissolution, resulting in lower nickel recovery after 24 Ah with the CaCl₂ electrolyte. Additionally, the critical point at which the electrogenerated oxidants, unable to attack the nickel, started to oxidize elemental sulphur to sulphate was reached at an earlier stage with the CaCl₂ electrolyte, i.e. after 16 Ah the selectivity of sulphide oxidation to sulphate was the same for NaCl and CaCl₂ (30–33%), whereas after 24 Ah 76% of the sulphide had been oxidized to sulphate with CaCl₂, as compared to only 39% with NaCl. Consequently, no further tests were carried out using CaCl₂.

3.5. Effect of current density

Two currents were investigated, 1 and 6 A (corresponding to current densities of 20 and 120 mA cm⁻², respectively), using the violarite concentrate with an

Table 3. Effect of using a calcium chloride electrolyte on sulphate removal when electroleaching a violarite concentrate.

	16 Ah		24 Ah	
	2 M NaCl	2 M CaCl ₂	2 M NaCl	2 M CaCl ₂
% nickel extraction	80.5	80.6	84.7	71.7
Sulphate in anolyte (g dm ⁻³)	14.0	2.4	16.5	0.4
Sulphate in catholyte (g dm ⁻³)	0.0	0.0	0.1	0.0
% sulphate in residue	10.8	85.7	7.2	99.1
% sulphate in solution	89.2	14.3	92.8	0.9
% distribution of sulphur:				
Sulphur as sulphate in residue	2.2	17.8	2.3	48.1
Sulphur as sulphate in solution	17.8	3.0	29.0	0.4
Elemental sulphur in residue	41.4	48.3	48.4	15.1
Sulphide in residue	38.6	30.9	20.3	36.4
Proportion of oxidized sulphur as:				
sulphate in residue	3.5	25.8	2.8	75.5
sulphate in solution	29.1	4.3	36.3	0.7
elemental sulphur in residue	67.4	69.9	60.9	23.8

Temperature 90°C; current 2 A; anolyte pH 3.

NaCl electrolyte. Figure 8 shows that nickel extraction per unit charge was greater at the lower current. This was because at the higher current the rate of oxidant generation exceeded that of metal dissolution. The excess oxidant was probably lost through chlorine gas evolution. There was no evidence to suggest that more sulphate was produced at the higher current.

Clearly, any potential electrohydrometallurgical process would have to balance the rate and amount of oxidant generation against the mineral oxidation rate and retention time to minimize costs.

3.6. Effect of particle size/pulp density

To determine the influence of particle size, a sample of the pentlandite concentrate was ground in a steel ball mill at 70% solids for 30 min. The size distribution of the as-received and ground pentlandite is given in Table 4. Figure 9 shows that grinding improved the nickel extraction at a given charge, and hence decreased the electrical energy consumption. For example, with the ground concentrate, 95% nickel extraction was obtained at an energy consumption of 10 kWh kg⁻¹ Ni after passing 14 Ah. This corresponds to a current efficiency of 67%. Dissolved iron remained below

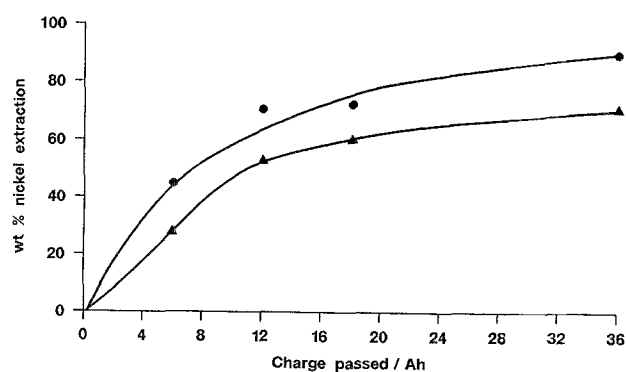

Fig. 8. Effect of charge passed on nickel extraction from the violarite concentrate at pH 3 and 90°C for currents of (●) 1 A and (▲) 6 A.

0.3%. The influence of particle size on the sulphur/sulphate balance is shown in Fig. 10. Below 14 Ah, sulphur production was favoured with the ground sample. However, as the charge was increased, sulphate formation became dominant.

Two pulp densities (13.5 and 38.5% solids) were tested using the pentlandite concentrate. Figure 11 shows that increasing the pulp density improved both nickel extraction and power consumption. This may be due to better utilization of the oxidant by the higher pulp density slurry, arising through greater contact between the chlorine and the mineral particles.

3.7. Combined electroleaching/electrowinning

Following the electroleaching study, tests were carried out to couple electroleaching with electrowinning in a one-step process. Table 5 gives a mass balance for a typical result obtained with the violarite concentrate. The cell was run continuously for 7 h at 2 A. The anolyte pH was controlled at 3 and the catholyte at 4. Under these conditions nickel plated out as a powder of greater than 99% purity, containing only 0.2%

Table 4. Size analysis of the pentlandite concentrate

Size fraction µm	Cumulative % passing	
	As-received	Ground
180	99.6	
125	98.5	
90	95.3	
63	89.2	
45	80.0	95.7
32	60.5	86.3
23	50.9	76.9
15	39.3	58.4
10	30.3	43.1
8	25.9	36.2
d ₅₀	22	13

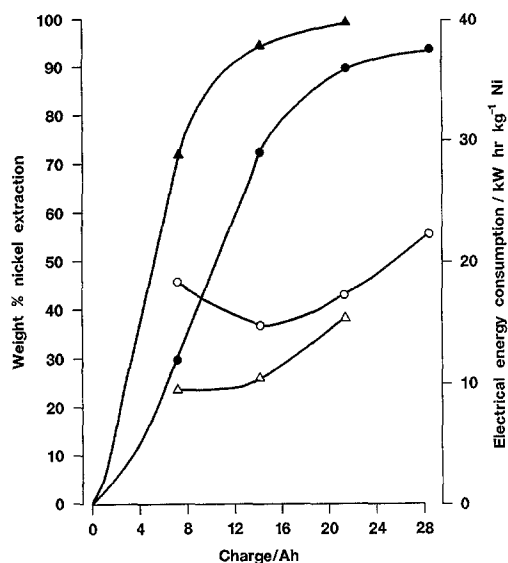

Fig. 9. Effect of charge passed on nickel extraction and electrical energy consumption (EEC) for the as-received and ground pentlandite concentrate with a current of 1 A at pH 3 and 90°C. As-received (●) % nickel, (○) EEC. Ground (▲) % nickel, (△) EEC.

iron. The power consumption to go from the concentrate to electrowon nickel was 21.4 kWh kg⁻¹ of recovered nickel. The current efficiency for nickel extraction was 23%, assuming violarite oxidation by Reaction 1. This reaction could account for all the elemental sulphur formed. Hence, if the sulphate is assumed to result from the oxidation of equal proportions of pyrite and pyrrhotite, via Reactions 10 and 11, then the measured sulphate levels indicate that 31% of the charge resulted in pyrrhotite oxidation, and 26% in the oxidation of pyrite. The remaining 20% of the charge was probably lost as unreacted oxidant. However, should some of the sulphate originate from the violarite, and some of the sulphur from the pyrite/pyrrhotite, as is likely, then the calculated

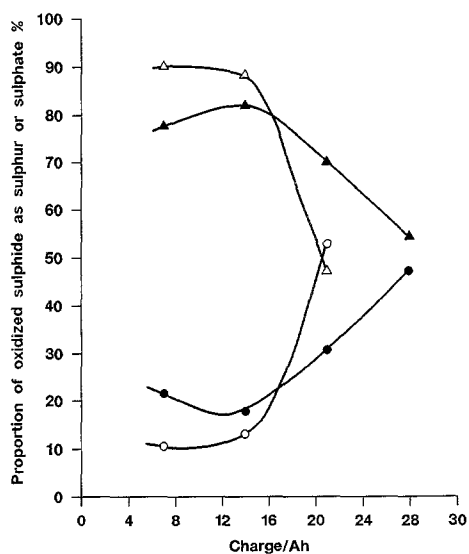

Fig. 10. Effect of charge passed on the selectivity of sulphur/sulphate production from the as-received and ground pentlandite concentrate with a current of 1 A at pH 3 and 90°C. As-received (▲) sulphur, (●) sulphate. Ground (△) sulphur, (○) sulphate.

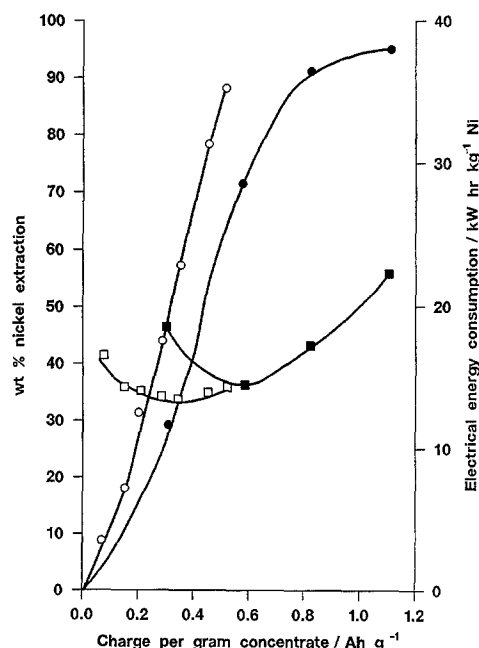

Fig. 11. Effect of charge passed on nickel extraction and electrical energy consumption (EEC) for the pentlandite concentrate at pulp densities of 13.5 and 38.5% solids with a current of 1 A at pH 3 and 90°C. 13.5% solids (●) % nickel, (○) % nickel, (■) EEC. 38.5% solids (□) EEC.

Table 5. Mass balance for a typical one-step electroleaching/electrowinning test with the violarite concentrate.

Nickel mass balance	g	% distribution
Nickel in ore feed (a)	3.28	100.0
Nickel in residue (b)	1.23	37.5
Nickel leached (a-b)	2.05	62.5
Nickel plated	1.96	59.7

Average cell voltage = 3 V
Power consumption to take concentrate to nickel powder = 21.4 kWh kg⁻¹ Ni

	Fe	Co	Cu
Nickel product contained (%)	0.2	0.3	0.1

Sulphur mass balance	g	% distribution
Total sulphur in ore feed	7.38	100.0
Sulphate in solution (c)	3.04	
Sulphate in residue (d)	0.41	
Total sulphate formed (c + d)	3.45	
Total sulphur as sulphate	1.15	15.5
Elemental sulphur formed	2.11	28.6
Sulphide in residue	4.04	54.7

Iron mass balance	g	% distribution
Amount in ore feed (e)	9.08	100.0
Amount in residue (f)	9.03	99.4
Amount leached (e-f)	0.05	0.6
Amount plated	0.004	0.04

Temperature = 90°C, current = 2 A for 7 h, anolyte pH 3, catholyte pH 4, Weight of concentrate feed 25.0 g

Table 6. Effect of pH and chloride ion concentration on the purity of nickel powder deposited at the cathode during the one step electroleaching–electrowinning of nickel

[Cl ⁻] /mol dm ⁻³	Anolyte pH	Catholyte pH	Analysis of nickel product/%			
			Ni	Fe	Co	Cu
2	3	2	87.2	12.4	0.38	0.02
2	3	3	93.2	6.3	0.48	0.02
2	3	4	99.4	0.2	0.32	0.08
2	3	5	98.7	0.9	0.30	0.10
5	3	5	92.8	6.4	0.54	0.26

distribution of charge will vary.

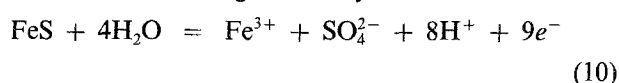

$$E = 0.114 - 0.053 \text{ pH} + 0.007 \log [\text{SO}_4^{2-}] + 0.007 \log [\text{Fe}^{3+}]$$

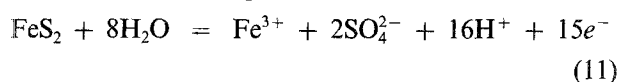

$$E = 0.394 - 0.063 \text{ pH} + 0.008 \log [\text{SO}_4^{2-}] + 0.004 \log [\text{Fe}^{3+}]$$

Table 6 shows that both the catholyte pH and the chloride concentration influenced the purity of the electrowon nickel. This was due to an accompanying increase in the solubility of the iron with increasing acidity or chloride concentration, enabling its transfer through the cation exchange membrane and subsequent codeposition at the cathode.

3.7.1. Drawbacks of single membrane cell. Although it would have been preferable to produce higher value nickel plate rather than nickel powder, it was not possible using a cell equipped with a single cation exchange membrane. This was because the cathode had to be operated with a low current efficiency for nickel deposition (about 20%) to ensure that the cathodic side reaction (hydrogen evolution) produced sufficient hydroxyl ions to balance the protons formed by both sulphide oxidation to sulphate, and goethite precipitation, in the anolyte. Thus, to ensure adequate hydroxyl generation, nickel electrowinning was carried out at currents above the mass transfer limited value for nickel deposition, and so a powdery deposit was obtained.

Another drawback of the single membrane cell was that hydrogen ion transfer across the membrane was not fast enough to maintain a constant pH. Ideally, the cell should be operated to produce a concentrated solution of sodium hydroxide in the catholyte. This solution could then be recirculated into the anolyte when required, its concentrated nature minimizing any reduction in pulp density. However, with a single membrane cell, generation of concentrated caustic in the catholyte leads to the precipitation of nickel hydroxide at the membrane surface, causing blockage and eventual membrane failure.

3.7.2. Alternative cell design. In order to overcome

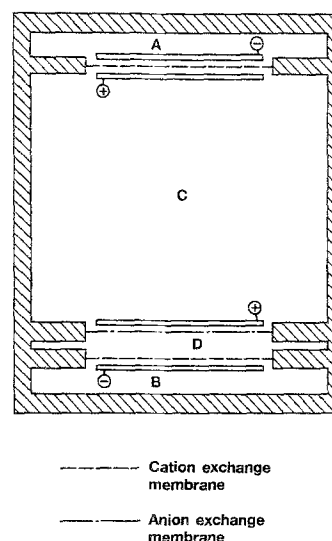

Fig. 12. Plan view of proposed electroleaching, electrolysis, electrowinning cell. A: cathode compartment for nickel electro-winning. B: cathode compartment for production of NaOH. C: slurry anode compartment. D: buffer zone of NaCl electrolyte.

these difficulties, an alternative cell design is proposed, though it has yet to be tested. A plan view of the cell is illustrated in Fig. 12. It incorporates an electro-dialysis unit to generate concentrated sodium hydroxide. The cathode housed in the electrowinning compartment (A) is operated at a lower current density than that used to generate hydroxyl ions (B), thereby allowing the production of nickel cathode rather than powder. Nickel electroleaching takes place in the central slurry compartment, (C). Soluble metal ions generated in this slurry anode compartment, and hydroxyl ions from the cathode compartment (B), are prevented from entering the sodium chloride buffer zone (D) by anion and cation exchange membranes, respectively. This prevents the precipitation of metal hydroxides on the surface of the membrane, and means that the concentrated caustic solution can be used to neutralize the protons formed in the anode compartment. The main disadvantages of the cell design are the large membrane area, and the increased anode–cathode interelectrode gap which results from incorporating an electro-dialysis section into the cell. These would increase the capital and running costs of the cell compared to the single membrane design.

4. Conclusions

The electroleaching of nickel from violarite and pentlandite iron–nickel sulphide concentrates has been studied, and the one step electroleaching–electrowinning of nickel demonstrated using an electrochemical cell fitted with a cation exchange membrane. Nickel powder of greater than 99% purity with an iron content of 0.2% was obtained.

Acknowledgements

The authors would like to thank BP Research for permission to publish this paper.

References

- [1] P. K. Everett, *Extractive Metallurgy* 81, London, IMM (1981) pp. 149-156.
- [2] P. R. Kruesi, E. S. Allen and J. L. Lake, *Can. Min. Metall. Bull.* June (1973) 81-87.
- [3] D. A. Dahlstrom, 4th meeting MMIJ - AIME, Tokyo, Japan (1980) pp. 23-40.
- [4] H. I. Philip, M. J. Nicol, A. M. E. Baleas, *Nat. Inst. Met. Report No. 1796*, April (1976), 30pp.
- [5] D. A. D. Boateng, C. R. Phillips, *Minerals Sci. Eng.* **10** (3) (1978) 163-171.